

Safe-Stop 90 Crash Cushion

Fully compliant with test 3-51 UK (110 kph)

The Safe-Stop 90 TMA is a totally unique design that provides maximum protection with minimal length and weight. The system measures a compact 3.98m long yet provides protection for design impacts of speeds up to 70mph.

Its two lightweight aluminium cartridges are contained in a reusable steel support frame. When impacted, the steel support frame collapses and the aluminium cartridges crush to absorb the energy of the impact.



- Passed all mandatory and optional tests including 3-51Uk of TD49/07 (70mph)
- Lightweight compact design
- Self contained hydraulic raise and lower
- Reusable steel frame after typical impact
- Resistant to nuisance damage

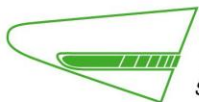
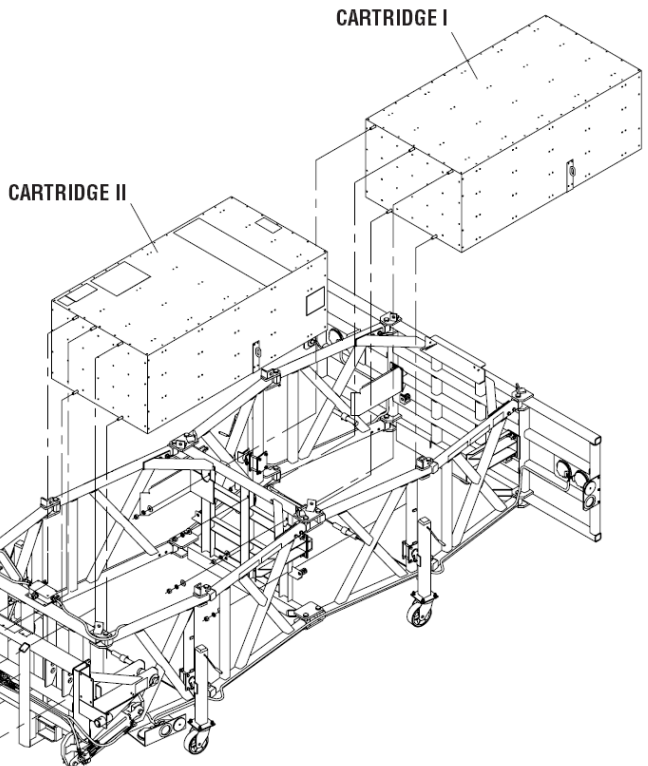

ENERGY ABSORPTION
SYSTEMS, INC.

A Quixote Company

King Highway Products Ltd

Riverside, Market Harborough, Leicestershire, LE16 7PX

Tel: 01858 467361 Fax: 01858 467161 email: sales@traiload.co.uk Web: www.traiload.co.uk

The company pursues a policy of continuous product development and reserves the right to make any changes to these specifications it considers necessary.